



# Next Generation Data Center Infrastructure

## ICE Cube™ Modular Data Center Overview and Features



**on365**, Weldon Road, Loughborough,  
Leicestershire, LE11 5RN  
**email:** [supportingtechnology@on365.co.uk](mailto:supportingtechnology@on365.co.uk)  
**tel:** +44 (0) 1509 261100  
**fax:** +44 (0) 1509 261168  
**web:** [www.on365.co.uk](http://www.on365.co.uk)



TABLE OF CONTENTS

**Introduction to ICE Cube ..... 3**

    ICE Cube Features..... 4

        Rapid Deployment of Systems .....4

        Lower Capital Costs .....4

        Lower Operational Expenses ..... 4

        Security..... 4

        Density..... 5

        Reliability..... 5

**ICE Cube Power ..... 6**

    Power Consumption .....6

    Power and Mobility ..... 7

    Smart DC Bus Bars ..... 7

    UPS ..... 7

**ICE Cube Cooling ..... 8**

    Heat Exchangers .....8

    Environment ..... 9

    Water Connections .....9

**ICE Cube Rack Configuration ..... 10**

**ICE Cube Monitoring ..... 11**

    Fire protection ..... 11

**ICE Cube Capacities and Container Specifications ..... 12**

## Introduction to ICE Cube™

SGI® offers a compelling alternative to augment or replace traditional brick-and-mortar data centers, as they relate to deployment of servers, networking and storage. ICE Cube is a self-contained, fully portable data center module featuring extreme server and storage density with highly efficient cooling and easy serviceability. ICE Cube features compute density levels of up to 22,400 cores or storage capacity of 11.0 petabytes in a compact 40' x 8' shipping container. Each container is self-contained as a cohesive system with no additional external structures required.

Designed to reduce data center costs, deployment times and maintenance, ICE Cube is ideal for organizations looking to maximize TCO and easily expand their existing data centers, provide for disaster recovery or completely eliminate the need for expensive raised floor new data center construction. ICE Cube can be deployed in almost any location, and features self-contained cooling and leading Uninterrupted Power Supply (UPS) technologies.

ICE Cube leverages SGI's proven expertise in server, cabinet and power infrastructure to achieve high density in a small form factor. Its unique cooling technology dramatically reduces cooling costs by as much as 80% over a traditional data center, and enables the total elimination of system-level fans for further power reductions. ICE Cube also leverages SGI's award-winning, patented managed DC Power technology for maximum efficiency and reliability.

ICE Cube was designed for maximum density while minimizing power and cooling costs. A range of SGI's Rackable half-depth servers with processors from Intel and AMD are available. The customer's unique workload requirements and priorities dictate server type, processor and overall configuration.

The servers range from 1U to 4U and from one server board to four server boards per chassis. For example, the Rackable XE2208 server is the highest density server chassis featuring 4 server boards/32 processing cores and 8 HDDs within a 2U chassis. The XE2208 was designed specifically for the ICE Cube and can provide a maximum of 22,400 processing cores in a 40' ICE Cube container while also providing exceptional local storage density and capacity.

## ICE Cube Features

Below are features containerized Data Center Modules (DCM) bring forth, as exemplified in ICE Cube.

### Rapid Deployment of Systems

The containerized DCM enables delivery of systems pre-cabled and tested at the rack level. Historically, SGI built and delivered a row of racks; this led to DCMs built and delivered on wheels, cabled and tested as a finished unit with no need to unload at the data center; the cost of infrastructure implementation is dramatically reduced with ICE Cube.

### Lower Capital Costs

The DCM concept permits customers to “build as you go,” as it permits a much simpler facility, which can be acquired much later in the build process. For example, ICE Cube design allows the UPS to arrive and scale with the rack load; no additional equipment is left idle or over provisioned. The DCM allows for the power generation set to be a simple diesel generator (or a second utility feed) to each set of the modules, requiring no flywheel or elaborate synchronous phase balance. Air handlers are no longer needed.

### Lower Operational Expenses

The techniques employed in the ICE Cube module, including the circulating water loop for operations at much higher temperatures, can effectively remove 80 percent or more of the cooling costs from the data center cost equation.

ICE Cube also makes use of a proven concept in the Telco world of using distributed ELV 48vdc across a distributed single conversion UPS at the rack. This eliminates the sub-optimal and costly inversion stage of the UPS. A second revolutionary step utilized by ICE Cube is the elimination of all server fans. When the combined power draw of these fans is subtracted from the power draw of the 48vdc air handler impellers, it ends with a negative number and the entire air handling loop effectively operates in the black, giving back power to the energy equation. This is a stark contrast to air handlers taking almost one-half of the chiller power in a large modern data center.

SGI's distributed UPS utilizes the best of class high rate VRLA cells, with a float life in excess of three years at elevated temperatures. A key component of the UPS system is the modern distributed and automated, autonomous testing and reporting of the system as a whole at the full real system load without risk of server interruption (even with completely missing cells). If there are any damaged units during normal maintenance windows, the batteries or rectifier modules are safely and easily hot replaced. The overwhelming simplicity and reliability of this system overshadows the older, painful battery maintenance procedures and techniques.

### Security

The DCM can be far more secure than a typical data center, as it is a locked steel shielded entity, denying physical as well as visual entry to all but authorized personnel. The cube can be placed in remote locations, as well as in bunkers and armored buildings.

## Density

The DCM breaks historical density profile records by increasing the compute and heat power footprint by 10 times, allowing power densities beyond 1500W per square foot of complete data center space. If a customer is prepared to consider the stacking capability, the square foot density can be doubled.

## Reliability

The ICE Cube module should be the most reliable of all data center formats because the two least reliable parts of the server are removed — the AC power supply and the server chassis fans. In addition, through the use of DC power supplies, a pool of redundant power at the rack level is provided to all servers that utilize DC power supplies featuring 2 Million+ hours Mean Time To Failure (MTTF) vs. 100K hours delivered by most AC power supplies. Dual feed DC configurations allow entire incoming circuits to fail by connecting the spare circuits to the “B” feeds on all servers in the container, maintaining availability in the case of circuit failure. The impeller fans included in the ICE Cube cooling infrastructure have much higher MTTF characteristics than the depopulated server fans (not needed in ICE Cube deployments) and there are far fewer of them. This cooling strategy leads to higher rack-level reliability. When the rack level UPS option is installed, the UPS systems can be serviced live without risky and/or complex bypass procedures, further protecting from transients that traditional data center UPS systems often miss.

## ICE Cube Power

The ICE Cube system is flexible in terms of power, as it is configured for a number of different power delivery solutions, including but not limited to:

- AC feeds with the power converted from AC to DC at the rack level
- AC feeds with the phase/voltage conversion via internally mounted transformer then converted from AC to DC at the rack level
- Externally rectified DC power direct to the ICE Cube

By far the most energy efficient means of providing power to ICE Cube is via 480/277 VAC 3-phase 5-wire wye (3 phases + neutral + ground). This is the preferred power source since 480 VAC 3-phase splits into three 277 VAC circuits without requiring a supplemental PDU. One or more 277 VAC circuits are then rectified to -48 VAC DC at the rack level and distributed to servers. This can easily be made redundant with the ICE Cube Dual Feed DC power option.

### Enabling the ecological data center™

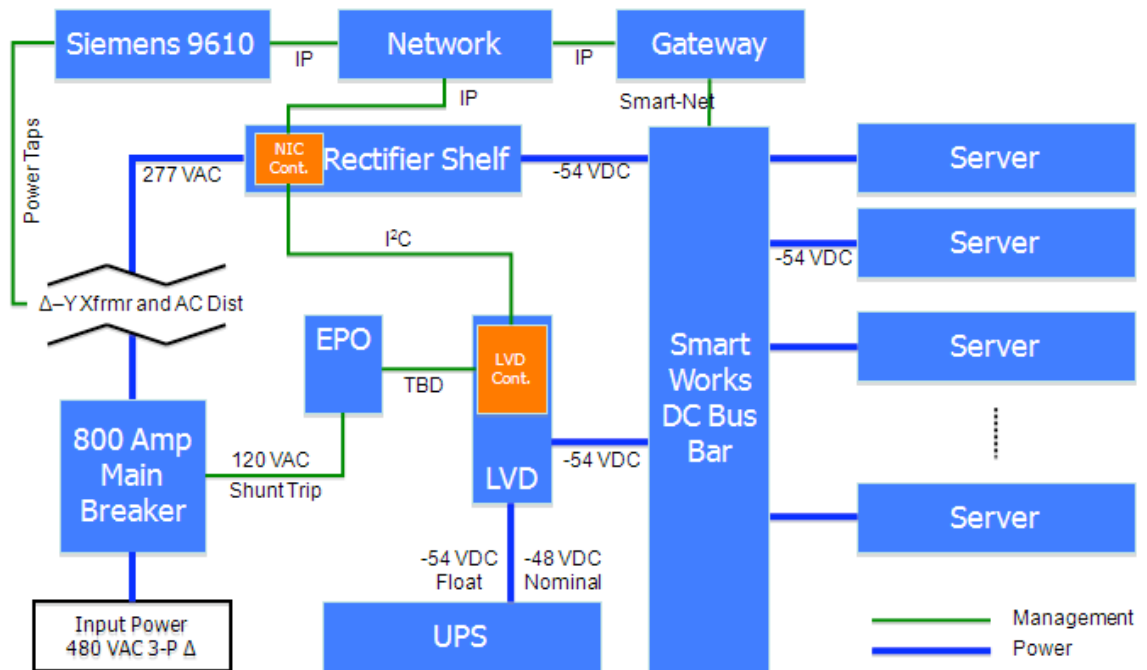

## Power Consumption

Within ICE Cube there are three primary sources of power draw beyond that of the servers. The cooling fans for a 40' 24-rack container consume less than 5000 Watts, although this power is more than offset because of the removal of all cooling fans inside the servers. Rectifiers are approximately 93% efficient, which results in additional power draw beyond the connected individual servers and fans. This is offset by the fact that the DC powered servers are between 4% and 8% more efficient than their AC powered equivalents. There is also a very minor power draw from overhead lighting and alarm panel (~50 W).

## Power and Mobility

There are multiple power feed and panel options, including 400A, dual 400A, 600A and even dual 600A. This flexibility is combined with an ability to configure the power panels for either a hard-wired stationary installation or a quick-disconnect mobile installation. Both models are equally supported.

## Smart DC Bus Bars

The Smart-Watt DC Rack Power Distribution Unit (RPDU) distributes 400 amps of 48 VDC power to 56 individual outlets. The RPDU has a network communications capability which allows customers to monitor volts, amps, watts and watt-hours for each individual outlet and the entire RPDU. Each outlet of the RPDU can also be controlled remotely (on/off) as well as measure power to each port.

## UPS

The ICE Cube solution includes a comprehensive rack level UPS system that meets the required two minute hold-up time. This system is tightly integrated into the DC power system and provides backup power to servers, network, cooling and other support equipment. It also includes an LDV and a fully integrated monitoring system. At the rack level, the system will consist of a 2U battery tray populated with four VRLA 12v cells with a 3-year service life. This provides for a highly scalable UPS system that can grow or shrink depending upon container/ server configuration. This can provide a baseline holdup time of 120 seconds or as much as 10 minutes.

## ICE Cube Cooling

ICE Cubes operate as closed-loop systems. The water source is either a chiller loop (including reservoir tank) or any untreated or poorly controlled source, as long as it goes through a heat exchange separation loop. Water should contain a simple organic algaecide and contain as little air as possible (a simple air breather vent should be installed high in the loop or a centrifugal air separator could be added). The cleaner and more air-free it is, the longer the cooling infrastructure will last. The ICE Cube cooling infrastructure has been designed to a 20-year specification to significantly outlive the 3–5 year service lives of most server and storage products.

Cooling load is totally dependent on server power draw. An estimate is approximately 300 tons of cooling on the chiller side per 1 megawatt of power draw. The typical deployment only requires about 900 hours chiller usage in a typical year when water side economizers are used.

## Heat Exchangers

SGL has designed a set of water cooled radiators with 10.8 PSI and a flow rate of 244 GPM for water in-let temperatures of 60F – 75F. As well, it can operate at lower temperatures and higher temperatures. Impeller fans are low power and operate at 90 Watts, with 6 fans per impeller unit.

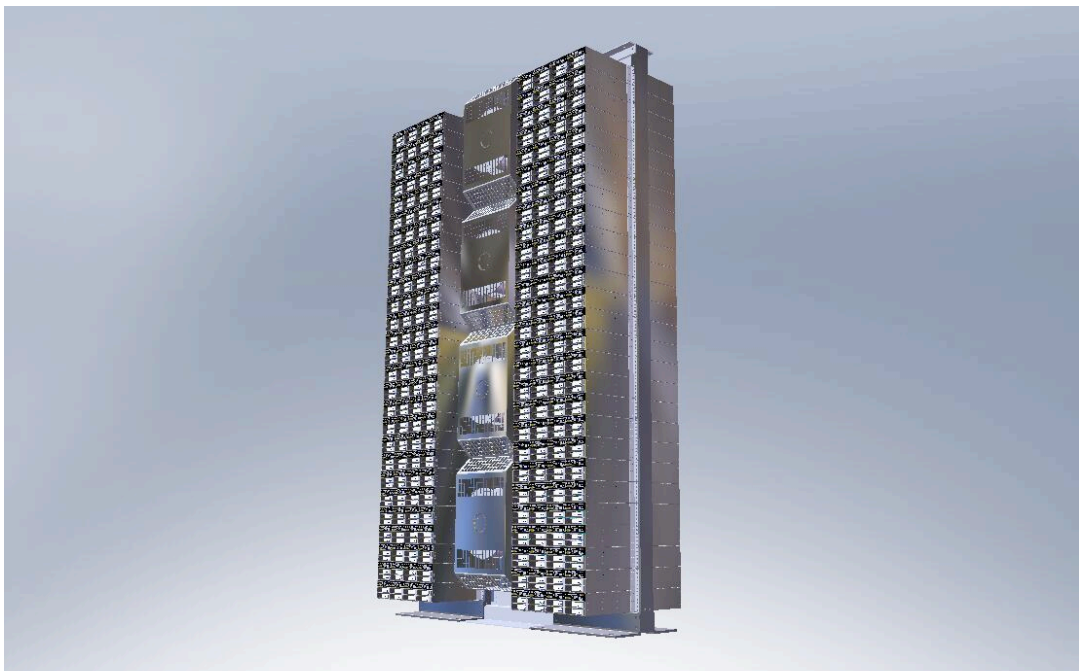

The radiators themselves are highly efficient units constructed similarly to units designed for installation in the harshest external environments. There is a 15-year design point. Each heat exchanger assembly serves a pair of racks, and airflow is drawn through the servers into a common plenum area behind the rack, then drawn through the heat exchanger and expelled, cooled into the center aisle.

The system is optimized to maintain the temperature swing inside the container cold aisle and server environment at about 5F with an inlet temperature of 75–85F. Operating ICE Cube at as high a temperature as possible is recommended to increase the number of free cooling hours per year and reduce condensation issues.

The water distribution system is plumbed primarily in copper pipe. This is utilized because of the increased resistance to internal corrosion, greater conductivity, lower initial cost and lower cost of installation.

## Environment

SGL has evaluated a wide variety of installation paradigms related to environmental parameters and determined there are no appreciable conflicts with any portion of ICE Cube in relation to functionality when installed indoors or out.

The ICE Cube container features a thermal, sound attenuation coating. The coating will block 95% of heat transfer, 68% of sound transfer and is resistant to moisture, mold and mildew. It has a class “A” fire rating with zero flame spread and smoke production.

## Water Connections

Water is usually supplied to ICE Cube via 2.5” grooved Victaulic connections (<http://www.victaulic.com/content/quickvicrigidcoupling.htm> ), with the stub leaving the container being a male end. A supply and a return line are provided on each side of the container (or end, if so configured). It is recommended that a simple 4” to 2.5” Victaulic “Y” be used about 12’ from the container, with the two supply and two return 2.5” hoses going to a 4” feed hose or line. A circuit setter can be placed on the 4” return line to set the flow, if so desired. A 4 or 8 bolt 4” flanged connection is also available as an alternate choice.

















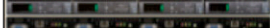



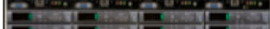
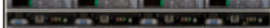





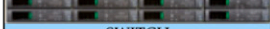



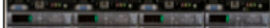



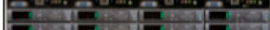

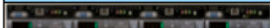

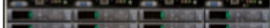

The design is simple, elegant, and durable.

# ICE Cube Rack Configuration

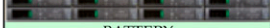
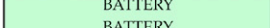



















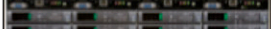





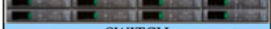











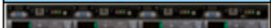



## Sample Rack-level Configuration

SGI has assembled the following sample rack-level configuration.

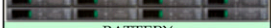
**23 SYSTEM LAYOUT**

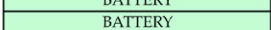
Row	RACK LAYOUT	System #
55	EMPTY	
54	RECTIFIER	
53	RECTIFIER	
52		23
51		
50		22
49		
48		21
47		
46		20
45		
44		19
43		
42		18
41		
40		17
39		
38		16
37		
36		15
35		
34		14
33		
32		13
31		
30	SWITCH	
29		12
28		
27		11
26		
25		10
24		
23		9
22		
21		8
20		
19		7
18		
17	SWITCH	
16		6
15		
14		5
13		
12		4
11		
10		3
9		
8		2
7		
6		1
5		
4	BATTERY	
3	BATTERY	
2	BATTERY	
1	BATTERY	

**22 SYSTEM LAYOUT**

Row	RACK LAYOUT	System #
55	EMPTY	
54	EMPTY	
53	EMPTY	
52	RECTIFIER	
51	RECTIFIER	
50		22
49		
48		21
47		
46		20
45		
44		19
43		
42		18
41		
40		17
39		
38		16
37		
36		15
35		
34		14
33		
32		13
31		
30	SWITCH	
29		12
28		
27		11
26		
25		10
24		
23		9
22		
21		8
20		
19		7
18		
17	SWITCH	
16		6
15		
14		5
13		
12		4
11		
10		3
9		
8		2
7		
6		1
5		
4	BATTERY	
3	BATTERY	
2	BATTERY	
1	BATTERY	

## ICE Cube Monitoring

SGI has designed a comprehensive monitoring system into the ICE Cube solution. The majority of the sensor package is sourced from West Coast Securities and includes collectible data points for the following:

- Free Water (leak) Detection
- Humidity level
- Smoke Detection
- Door open and entry alarm
- Temperature
- Security

Temperature, humidity, moisture and smoke detection monitoring are tied into the alarm system that also covers intrusion detection. Also, additional monitoring capabilities are available as required. The alarm system includes an evacuation horn and strobe. The System is fully capable of integration with various facility management systems. However it can also be operated independently through an optional integrated touch screen GUI. In addition, the system also includes a GPS tracking device that allows for real-time location monitoring during shipment.

### Fire protection

A customer specified fire/smoke protection system can be installed by SGI during manufacture, or customers can have their fire protection contractors work with our manufacturing team to assist in the installation of a compatible facilities monitoring system at the time of ICE Cube manufacture. Additionally, we have multiple optional fire protection/detection systems available including an FE-13 system and we continue to evaluate other potential options.

## ICE Cube Capacities and Container Specifications

### Container Level Specifications

	ICE Cube™ 2012	ICE Cube™ 4024	ICE Cube™ 4028
Length	20'	40'	40'
Width	8'	8'	8'
Height	9.5'	9.5'	9.5'
Tare Weight [without servers]	5, 500 lbs	9,000 lbs	9,000 lbs
Typical Weight [with servers]	~15–30k lbs [depending upon server count/ configuration]	~30–60k lbs [depending upon server count/ configuration]	~30–60k lbs [depending upon server count/ configuration]
Number of Racks	12	24	28
U per rack	55	55	55
Available U per rack [assumes 1U DC shelf & 2U of network gear]	52	52	52
Available U per container	624	1248	1486
Electrical Service Required	400A	400A	400A
277 VAC circuits per container	26	52	60
With Dual Feed option	16	28	32
Supply Air Temp Min/Max	Dew point/95F	Dew point/95F	Dew point/95F
Ideal Server Delta-T	10–12 F	10–12 F	10–12 F
Supply Water Temp Min/Max	40–75 F	40–75 F	40–75 F
Ideal Supply Water Temp	65 F	65 F	65 F
Water Flow Min/Max [GPM]	100/200	100/200	100/200
Ideal Water Flow [GPM]	135	135	135
Water Delta-P [ft head]	30	30	30

We also recommend the Ice Cube Installation Overview and Service Offerings White Paper:

<http://www.sgi.com/pdfs/4172.pdf>